



DIECI



Dieci S.r.l.
Via E. Majorana, 2-4
42027 - Montecchio Emilia (RE) ITALY
Tel. +39 0522 869611
Fax +39 0522 869798
E-mail: info@dieci.com

SAMSON



45.8

60.9

60.9 *vs*

65.8

65.8 *vs*

75.10

PERFORMANCE	45.8	60.9	60.9 VS	65.8	65.8 VS	75.10
Maximum capacity on outriggers (kg)	-	-	-	-	-	7.500
Maximum capacity on tires (kg)	4.500	6.000	6.000	6.500	6.500	7.200
Maximum lifting height (m)	7,90	8,60	8,60	7,70	7,70	9,65
Maximum horizontal outreach (m)	4,45	4,90	4,90	4,20	4,20	5,40
Outreach at maximum height (m)	0,30	0,45	0,45	0,60	0,60	0,70
Fork swivelling angle	134°	144°	144°	144°	144°	134°
Pull-out force (daN)	5.700	7.500	7.500	7.500	7.500	8.750
Towing force (daN)	7.300	7.600	8.800	7.600	8.800	8.400
Maximum climb angle	40%	40%	40%	40%	40%	40%
Total weight empty (kg)	8.800	11.100	11.100	10.900	10.900	12.100
Max speed (km/h) *	40	40	40	40	40	40

* = refers to wheels with maximum admissible diameter

ENGINE	45.8	60.9 - 60.9 VS 65.8 - 65.8 VS 75.10	
Model:	Kubota	FPT	FPT
Rated power kW (hp) @ 2600 rpm:	85 (114)	/	/
Rated power kW (hp) @ 2200 rpm:	/	96 (130)	103 (140)
Peak power kW (hp) @ 1900 rpm:	/	105 (141)	113 (152)
Revolutions per minute (rpm):	2600	2200	2200
Operation:	4-stroke diesel		
Injection:	Electronic direct, Common Rail		
Number and arrangement of cylinders:	4, vertical in line		
Engine size (cm³):	3769	4500	4500
Specific consumption - (g/kWh):	227	208	208
Exhaust gas after treatment system:	DPF	SCR	SCR
* at maximum power	Stage 3B / Tier 4i		
Aftercooler turbo compressor	Liquid cooling system		

BOOM	45.8	60.9	60.9 VS	65.8	65.8 VS	75.10
	Times: empty (in seconds)					
Lifting	13,0	13,4	11,0	12,8	10,5	15,1
Descent	8,9	8,4	6,9	8,0	6,6	9,9
Extension	6,8	7,8	6,4	6,7	5,5	10,4
Retraction	3,8	3,4	2,8	3,0	2,4	4,1
Forward swivelling	3,3	3,5	2,8	3,5	2,8	4,6
Reverse swivelling	2,0	2,3	1,9	2,3	1,9	2,0
	Patented compensation system					

OPTIONALS AND ACCESSORIES

A/C; Water Heater; Driver's seat with pneumatic suspension; LED light on boom;

Quick coupling for accessories; Radio; Anti-theft system; Glass protection. LED work lights.

(For additional customisation, contact the area dealer)

HYDRAULIC SYSTEM	45.8
Gear pump with capacity at max. speed (lt/1'):	170
Max operational pressure (bar):	240
Distributor control with joystick:	4 in 1

HYDRAULIC SYSTEM	60.9 VS - 65.8 VS
Variable delivery pump (Load Sensing) (lt/1'):	200
Max operational pressure (bar):	250
Distributor control with joystick:	4 in 1

HYDRAULIC SYSTEM	60.9 - 65.8 - 75.10
Gear pump with capacity at max. speed (lt/1'):	160
Max operational pressure (bar):	250
Distributor control with joystick:	4 in 1

DIFFERENTIAL AXLES

Steering axles: 2, with planetary reduction gears

Steering types: 4-wheel / Transverse / 2-wheel

Front axle: rigid (levelling upon request)

Back axle: oscillating

Oil bath service brake on the 4 wheels with double hydraulic system and servo brake

Negative action parking brake

REFUELLING (Litres)	45.8	60.9 - 60.9 VS 65.8 - 65.8 VS	75.10
Hydraulic system (total)	155	160	160
Diesel tank	105	125	105
AdBlue tank	27	35	

TRANSMISSION

Hydrostatic transmission with variable displacement pump.

Hydrostatic engine with automatic variation.

Electrical - hydraulic inversion.

Inching pedal for controlled advancement.

Servocontrolled 2-speed gearbox.

TRANSMISSION (for VS models)

Vario System EVO 2 hydrostatic transmission.

Electro-hydraulic reverse gear control.

Drive Mode: Automotive / Loader / Creeper / Eco.

Electronic inching pedal.

TOWING CAPACITY	60.9 - 60.9 VS 65.8 - 65.8 VS
Trailer without brakes (t):	6
Inertia braking (t):	9
Mechanical braking (t):	6
Hydraulic/pneumatic braking (t):	20

DEVICES AS PER STANDARD

Anti-tipping device with hazardous movement block.

Hydraulic socket for any accessories on the boom head.

Soundproof closed cab, ROPS-FOPS approved, with heating.

Self-blocking front axle differential (limited slip 45%).

Electric window winder. Colour LCD display. Grid heater. Digital speedometer.

TYRES	45.8	60.9 - 60.9 VS 65.8 - 65.8 VS	75.10
Tyres	405/70x20"	18-22.5"	18-22.5"
* Alternative	405/70x24"	17,5-25"	18R22.5"
** Alternative	18-22.5"	500/70R24"	-
** Alternative	18R22.5"	-	-

DIMENSIONS	45.8	60.9	60.9 VS	65.8	65.8 VS	75.10
A/A*/A**	440/480*	395/470*/445**	395/470*/445**	395/470*/445**	395/470*/445**	440
B	1480	1505	1505	1155	1155	1630
C	2600	2800	2800	2800	2800	2950
D	860	1050	1050	1050	1050	1330
E/E*/E**	4000/4050*	4435/4520*/4495**	4435/4520*/4495**	4435/4520*/4495**	4435/4520*/4495**	4820
F	4940	5355	5355	5005	5005	5910
G	940	940	940	940	940	940
H/H*/H**	2460/2500*	2495/2570*/2545**	2495/2570*/2545**	2495/2570*/2545**	2495/2570*/2545**	2490
I/I*/I**	1910	1920/1975*/1950**	1920/1975*/1950**	1920/1975*/1950**	1920/1975*/1950**	1920
L/L*/L**	2310	2390/2420*/2450**	2390/2420*/2450**	2390/2420*/2450**	2390/2420*/2450**	2380
M	4080	4550	4550	4350	4350	4730
N	1260	1700	1700	1700	1700	1700
O	3920	4400	4400	4400	4400	4400

Measurements expressed in millimetres

(*) - (**) = Measurements referring to optional wheels

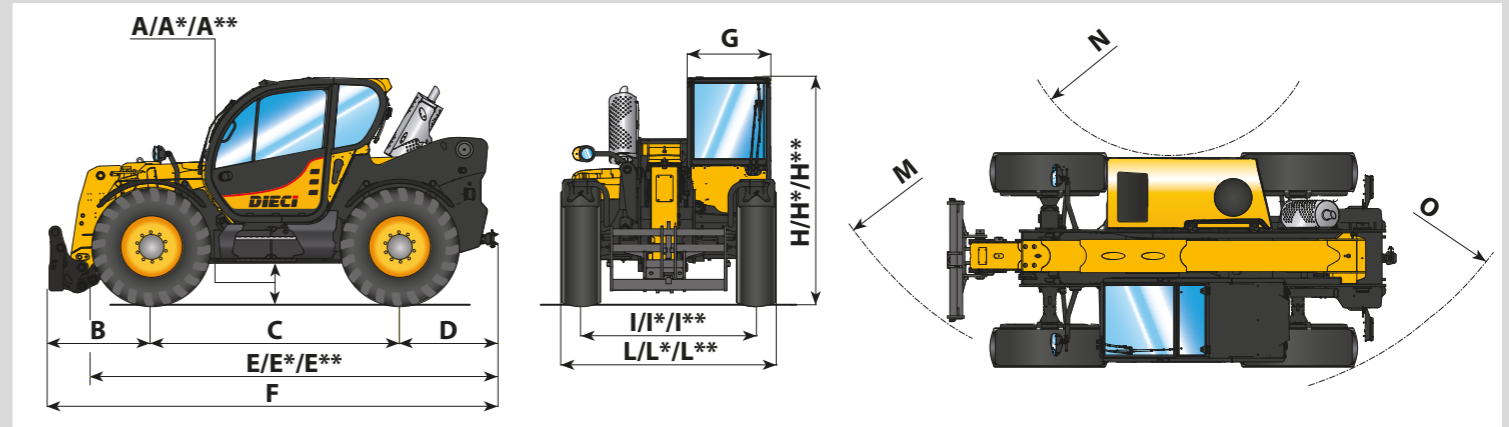

A* - E* - H* = Measurements referring to optional wheels

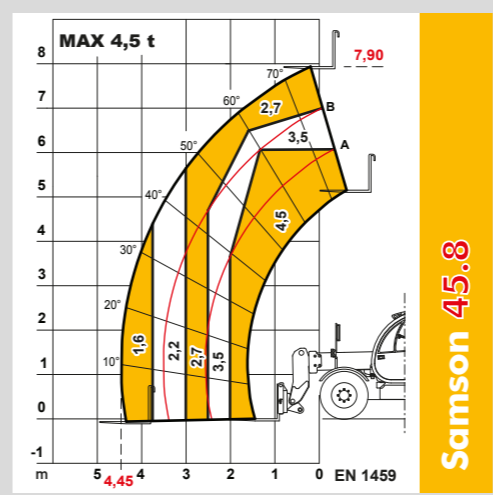

Samson 45.8

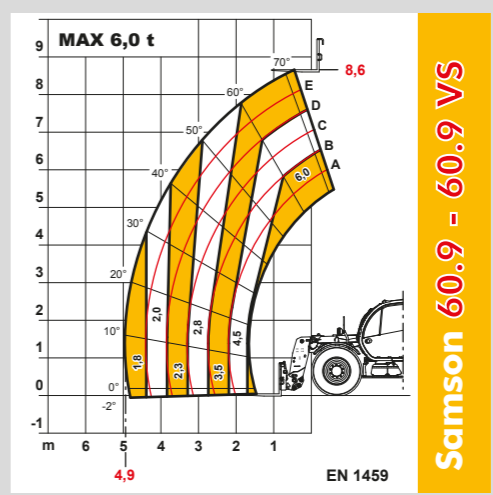

Samson 60.9 - 60.9 VS

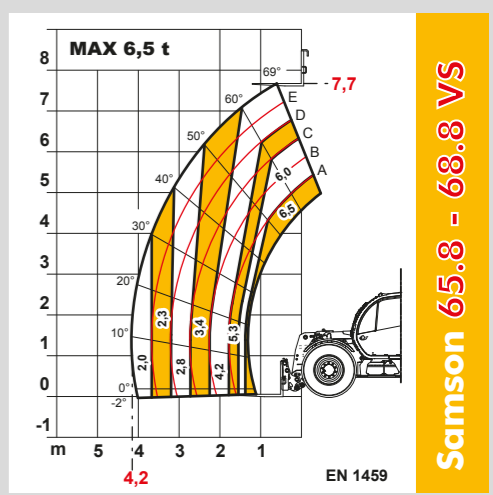

Samson 65.8 - 68.8 VS

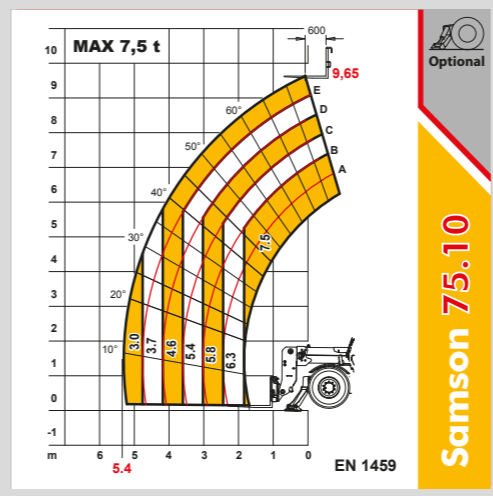

Samson 75.10

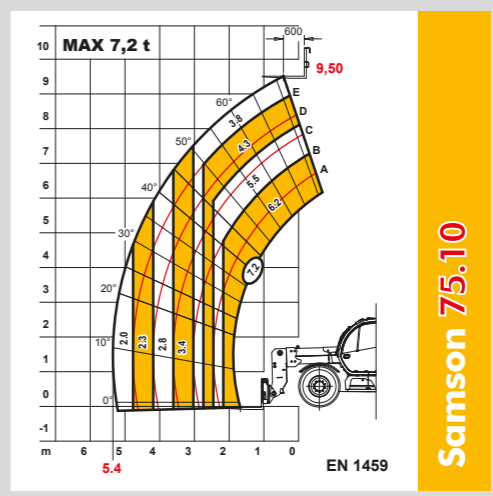

Samson 75.10