



DIECI



Dieci S.r.l.
Via E. Majorana, 2-4
42027 - Montecchio Emilia (RE) ITALY
Tel. +39 0522 869611
Fax +39 0522 869798
E-mail: info@dieci.com

AGRI FARMER



32.6

28.7

28.9

30.7

30.9

PERFORMANCE	32.6	28.7	30.7	28.9	30.9
Maximum capacity (kg)	3.200	2.800	3.000	2.800	3.000
Maximum lifting height (m)	6,00	6,35	6,35	8,70	8,70
Maximum horizontal outreach (m)	3,30	3,65	3,65	5,70	5,70
Outreach at maximum height (m)	0,66	0,80	0,80	0,80	0,80
Fork swivelling angle	146°	146°	146°	146°	146°
Pull-out force (daN)	5.700	5.700	5.700	5.700	5.700
Towing force (daN)	5.500	5.500	5.500	5.500	5.500
Maximum climb angle	40%	40%	40%	40%	40%
Total weight when empty (kg)	5.900	6.100	6.100	6.250	6.250
Max speed (km/h) *	35	35	35	35	35

* = referred to wheels having the maximum allowable diameter

BOOM	32.6	28.7	30.7	28.9	30.9
Times (in seconds)					
Lifting	5,9	7,4	7,4	9,0	9,0
Descending	3,1	3,9	3,9	4,7	4,7
Extension	4,9	5,7	5,7	5,2	5,2
Retraction	2,7	3,2	3,2	2,9	2,9
Forward swivel	2,5	3,2	3,2	3,2	3,2
Backward swivel	1,6	2,1	2,1	1,7	1,7

Patented compensation system

ENGINE

Model:	Kubota
Maximum power kW (hp):	74.5 (101)
Revolutions per minute (rpm):	2600
Operation:	4-stroke diesel
Injection:	Electronic direct, Common Rail
Number and arrangement of cylinders:	4, vertical in line
Displacement (cm ³):	3769
Specific consumption at 2600 rpm (g/kWh):	231
After-treatment exhaust gas system	DPF (Stage 3B / Tier 4i)
	Turbo compressor
* at maximum power	Liquid cooling system

HYDRAULIC SYSTEM

	32.6	28.7 - 30.7 28.9 - 30.9
Gear pump with max speed capacity (lt/1'):	115	115
Max operating pressure (bar):	245	230
Distributor control with joystick:	4 in 1 electro-proportional	

DIFFERENTIAL AXLES

Steering axles: 2, with planetary reduction gears
Steering types: 4-wheel / transversal / 2-wheel
Front axle: rigid
Rear axle: oscillating
Oil bath service braking on the front axle with servo-brake
Negative action parking brake.

For machines with "Tractor" approval:

Service brake in oil bath on the 4 wheel with a double hydraulic system and servo-brake

REFUELLING (Litres)

Hydraulic system (total)	110
Diesel tank	100

OPTIONALS AND ACCESSORIES

A/C; Water heaters; Pneumatic suspension seat; Headlight on boom head; Quick coupling for accessories; Radio; Anti-theft system; Window protection. LED work lights.

(For additional customizations, contact the local dealer)

TRANSMISSION

Hydrostatic transmission with variable displacement pump.
Hydrostatic engine with automatic variation.
Electrical - hydraulic reversing.
Inching pedal for controlled advancement.
Servocontrolled 2-speed gearbox.

STANDARD DEVICES

Anti-tipping device with pejorative movement block.
Hydraulic socket for any accessories on the boom head.
Soundproof closed cab, ROPS-FOPS approved, with heating.
Self-blocking differential front axle (limited slip 45%).
Self-cleaning filter with cyclone filters.
Electric window winder.
LCD display. Digital speedometer.

TOWING CAPACITY (on request)

Trailer without brakes (t):	6
Inertia braking (t):	6
Mechanical braking (t):	6
Hydraulic/pneumatic braking (t):	17

Includes 20" wheels

TYRES

	32.6	28.7 28.9	30.7 30.9
Tyres	405/70x20"	405/70x20"	405/70x20"
(*) Alternative	405/70x24"	405/70x24"	405/70x24"

DIMENSIONS	32.6	28.7	30.7	28.9	30.9
A/A*	400/440*	400/440*	400/440*	400/440*	400/440*
B	1195	1315	1315	1232	1232
C	2600	2800	2800	2800	2800
D	700	650	650	743	743
E/E*	3840/3890*	3990/4040*	3990/4040*	4087/4137*	4087/4137*
F	4495	4765	4765	4775	4775
G	940	940	940	940	940
H/H*	2240/2280*	2040/2080*	2220/2260*	2040/2080*	2220/2260*
I	1600	1600	1600	1600	1600
L	2000	2000	2000	2000	2000
M	4830	4900	4900	4900	4900
N	1530	1670	1670	1670	1670
O	3910	4000	4000	4000	4000

Measurements expressed in millimetres

(*) = Measurements referring to optional wheels

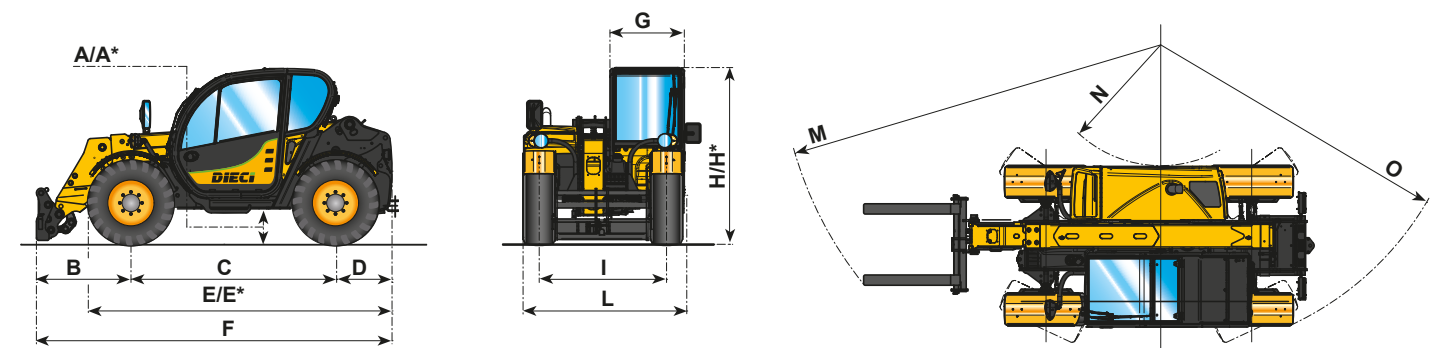

(*) = Measurements referring to optional wheels

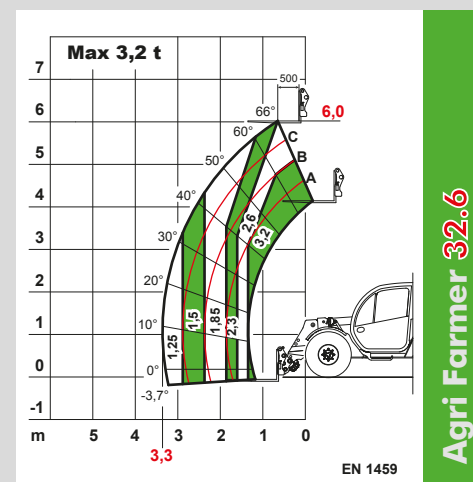

Agri Farmer 32.6

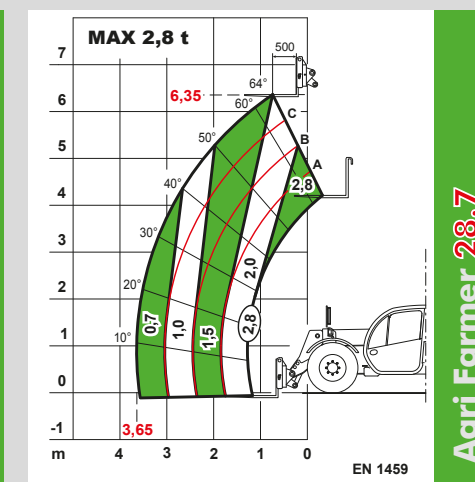

Agri Farmer 28.7

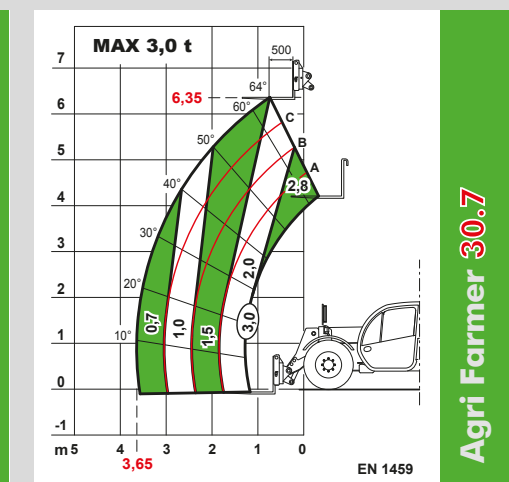

Agri Farmer 30.7

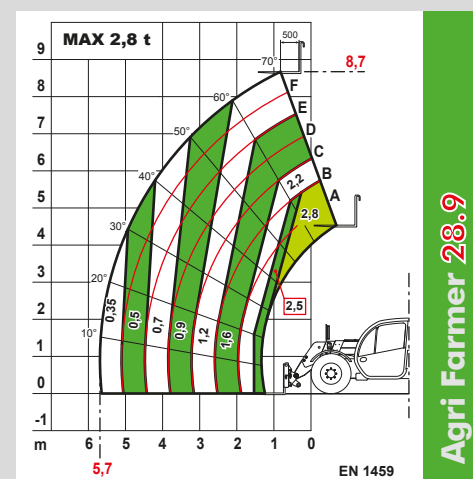

Agri Farmer 28.9

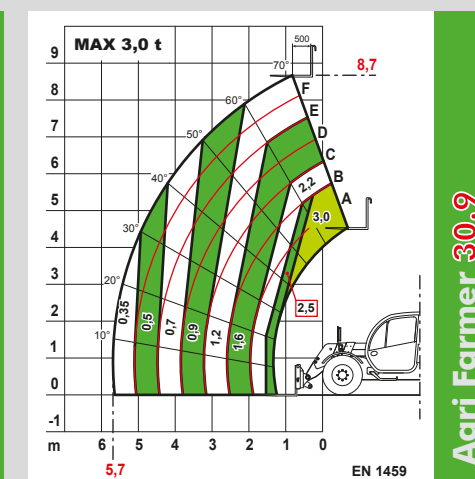

Agri Farmer 30.9