



DIECI



RUNNER



Dieci S.r.l.
Via E. Majorana, 2-4
42027 - Montecchio Emilia (RE) ITALY
Tel. +39 0522 869611
Fax +39 0522 869798
E-mail: info@dieci.com

35.7

40.13

PERFORMANCE	35.7	40.13
Maximum capacity (kg)	3.500	4.000
Maximum lifting height (m)	7,30	12,40
Maximum horizontal outreach (m)	3,85	8,75
Outreach at maximum height (m)	0,00	1,40
Fork swivelling angle	134°	134°
Pull-out force (daN)	5.700	5.700
Towing force (daN)	7.300	7.300
Maximum climb angle	40%	40%
Total weight empty (kg)	8.020	10.420
Max speed (km/h) *	40	40

* = referred to wheels having the maximum allowable diameter

BOOM	35.7	40.13
Times empty (in seconds)		
Lifting	11,8	10,0
Descent	6,9	5,9
Extension	7,0	18,6
Retraction	3,9	13,6
Forward swivelling	3,9	3,3
Reverse swivelling	2,4	2,1

Patented compensation system

ENGINE	
Model:	Kubota
Maximum power kW (hp):	85 (114)
Revolutions per minute (rpm):	2600
Operation:	4-stroke diesel
Injection:	Electronic direct, Common Rail
Number and arrangement of cylinders:	4, vertical in line
Displacement (cm ³):	3769
Specific consumption at 2600 rpm (g/kWh):	227
	Aftercooler turbo compressor
* at maximum power	Liquid cooling system

HYDRAULIC PLANT	
Gear pump with capacity at max. speed (lt/1'):	170
Max operational pressure (bar):	250
Distributor control with joystick:	4 in 1

DIFFERENTIAL AXLES	
Steering axles: 2, with planetary reduction gears	
Steering types: 4 wheels / transversal / 2 wheels	
Front axle: rigid (levelling upon request)	
Back axle: oscillating	
Oil bath service braking on the 4 wheels with double hydraulic plant and servo brake	
Negative action parking brake	

REFUELLING (Litres)	35.7	40.13
Hydraulic plant (total)	155	168
Fuel tank	105	105

OPTIONALS AND ACCESSORIES	
A/C; Webasto Heater; Water Heater; Driver's seat with pneumatic suspension;	
Light on boom head; Quick coupling for accessories; Radio; Anti-theft system;	
Glass protection. LED work lights.	
(For additional customizations, contact the area dealer)	
TRANSMISSION	
Hydrostatic transmission with variable displacement pump.	
Hydrostatic engine with automatic variation.	
Electrical - hydraulic inversion.	
Inching pedal for controlled advancement.	
Servocontrolled 2-speed gearbox.	

DEVICES AS PER STANDARD	
Anti-tipping device with pejorative movement block.	
Hydraulic socket for any accessories on the boom head.	
Soundproof closed cab, ROPS-FOPS approved, with heater.	
Self-blocking front axle differential (limited slip 45%).	
Electric window winder. Digital speedometer.	
Only on the following models: 40.13	
Independent hydraulic tipping outriggers	

TYRES	
Tyres	405/70x20"
Alternative	405/70x24"
Alternative	18-22.5"
Alternative	18R22.5"

DIMENSIONS	35.7	40.13
A/A*	440/480*	440/480*
B	1180	2110
C	2600	2600
D	860	880
E/E*	4000/4050*	4080/4130*
F	4640	5590
G	940	940
H/H*	2460/2500*	2460/2500*
I	1910	1910
L	2310	2320
M	N.A.	2480
N	3930	4550
O	1260	1260
P	3920	3920

Measurements expressed in millimetres

A* - E* - H* = Measurements referring to optional wheels

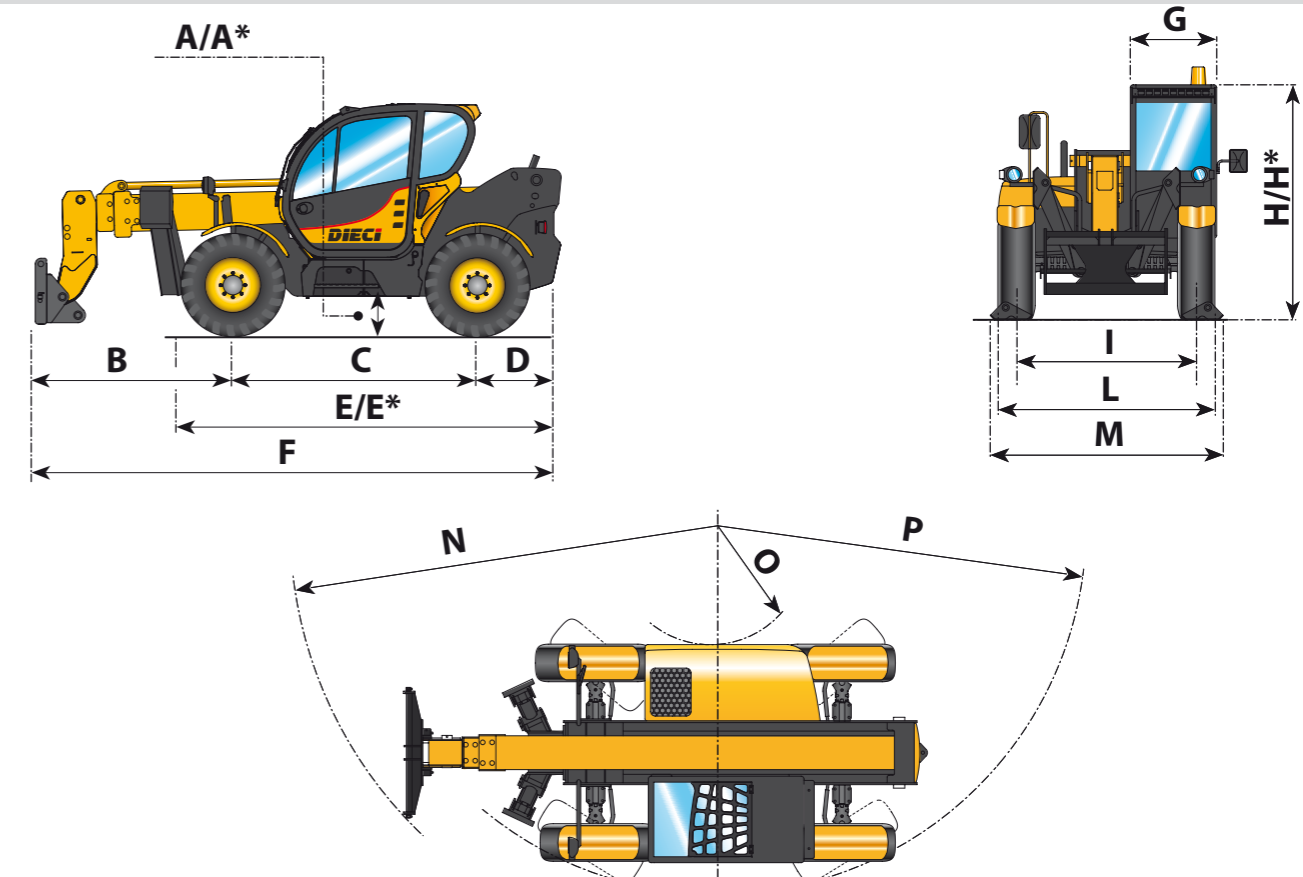

A* - E* - H* = Measurements referring to optional wheels

