



DIECI



Dieci S.r.l.
Via E. Majorana, 2-4
42027 - Montecchio Emilia (RE) ITALY
Tel. +39 0522 869611
Fax +39 0522 869798
E-mail: info@dieci.com

ICARUS



40.14

40.17

PERFORMANCE	40.14	40.17
Maximum capacity (kg)	4.000	4.000
Maximum lifting height (m)	13,50	16,90
Maximum horizontal outreach (m)	9,30	12,70
Outreach at maximum height (m)	1,10	1,15
Fork swivelling angle	134°	134°
Pull-out force (daN)	5.700	5.700
Towing force (daN)	7.300	7.300
Gradeability	40 %	40 %
Total weight empty (kg)	10.900	12.260
Max speed (km/h) *	35*	35*

* = referred to wheels with maximum admitted diameter

BOOM	40.14	40.17
Times: empty (in seconds)		
Lifting	12,3	14,1
Descent	8,4	10,2
Extension	21,4	21,4
Retraction	15,6	14,1
Forward swivelling	3,3	3,3
Reverse swivelling	2,1	2,1

Patented compensation system

ENGINE	
Model:	Kubota
Maximum power kW (hp):	85 (114)
Revolutions per minute (rpm):	2600
Operation:	4-stroke diesel
Injection:	Electronic direct, Common Rail
Number and arrangement of cylinders:	4, vertical in line
Displacement (cm³):	3769
Specific consumption at 2600 rpm (g/kWh):	227
	Aftercooler turbo compressor
* at maximum power	Liquid cooling system

HYDRAULIC PLANT	
Gear pump with capacity at max. speed (lt/1'):	170
Max operational pressure (bar):	250
Distributor control with joystick:	4 in 1

DIFFERENTIAL AXLES	
Steering axles: 2, with planetary reduction gears	
Steering types: 4 wheels / transversal / 2 wheels	
Front axle: rigid (levelling upon request)	
Back axle: oscillating	
Oil bath service braking on the 4 wheels with double hydraulic plant and servo brake	
Negative action parking brake	

REFUELLING (Litres)	
Hydraulic plant (total)	174
Fuel tank	105

OPTIONALS AND ACCESSORIES	
A/C; Water Heater; Driver's seat with pneumatic suspension; Light on boom head;	
Quick coupling for accessories; Radio; Anti-theft system; Glass protection. Led work lights.	
(For additional customizations, contact the area dealer)	

TRANSMISSION	
Hydrostatic transmission with variable displacement pump.	
Hydrostatic engine with automatic variation.	
Electrical - hydraulic inversion.	
Inching pedal for controlled advancement.	
Servocontrolled 2-speed gearbox.	

DEVICES AS PER STANDARD	
Anti-tipping device with pejorative movement block.	
Independent hydraulic tipping outriggers.	
Hydraulic socket for any accessories on the boom head.	
Soundproof closed cab, ROPS-FOPS approved, with heater.	
Self-blocking front axle differential (limited slip 45%).	
Electric window winder. Digital speedometer.	

TYRES	40.14	40.17
Tyres	405/70x20"	405/70x24"
Alternative	405/70x24"	18-22.5"
Alternative	-	18R22.5"

DIMENSIONS	40.14	40.17
A/A*	390 / 440*	440
B	1900	1970
C	2950	2950
D	1415	1415
E/E*	4905 / 4955*	4955
F	6245	6295
G	940	940
H/H*	2500 / 2555*	2555
I	1950	1950
L	2360	2360
M	3270	3270
N	4900	4900
O	1700	1700
P	4400	4400

Measurements expressed in millimetres

A* - E* - H* = Measurements referring to optional wheels

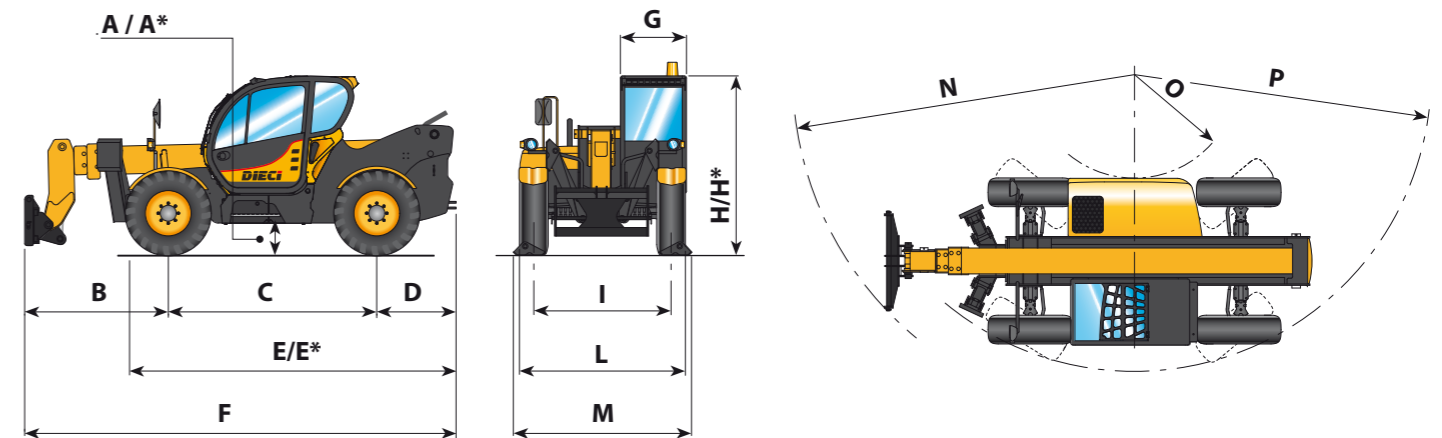

A* - E* - H* = Measurements referring to optional wheels

