

T 40      T 50      T 60      T 70      T 80

**AGRI PIVOT**

PERFORMANCE	T40	T50	T60	T70	T80
Operating load with standard bucket and quick connection (kg)	4950	5470	6020	7150	8000
Standard bucket capacity (m <sup>3</sup> )	0,75	0,85	0,95	1,10	1,20
Breakout force (daN)	4075	4550	4800	6000	6700
Maximum negotiable gradient	60%	70%	80%	80%	80%
Traction force (daN)	3400	4200	4700	6000	6500
Max speed (km/h)	22	30	40	40	36

BOOM	T40	T50	T60	T70	T80
Times: (in seconds)					
Lifting	7,3	5,0	5,4	5,3	5,3
Descent	3,8	2,7	2,9	3,0	3,0
Extension	2,5	2,3	2,5	2,3	3,2
Retraction	1,4	1,1	1,3	1,2	1,8
Tilt (Recall)	2,2	1,9	1,9	2,1	2,4
Tilt (Unloading)	1,6	1,3	1,3	1,3	1,6

Patented compensation system

ENGINE	T40	T50	T60	T70	T80
Brand	KUBOTA	KUBOTA	KUBOTA	KUBOTA	FPT
Maximum power kW (hp)	36,5 (50)	55.4 (74.3)	55.4 (74.3)	85 (115)	107 (145)
Speed setting (rpm)	2700	2600	2600	2600	2200
Operation	4-stroke Diesel		4-stroke Diesel		
Injection	Direct mechanical		Direct, electronic		
Number and arrangement of cylinders	4, vertical in line		4, vertical in line		
Displacement (cm <sup>3</sup> )	2615	3331	3331	3769	4500
Specific consumption (g/kWh)*	235	247	247	227	205
Intake	Natural		Turbo compressor intercooler		
Cooling system	Liquid		Liquid		
Starting VOLTS	12	12	12	12	12
* at maximum power	Stage 3B / Tier 4 final		Stage 3B / Tier 4i		Stage 4 / Tier 4 final

HYDRAULIC PLANT	T40	T50	T60	T70	T80
Variable displacement piston pump with max. flow rate at full operation (lt/1'):	-	-	-	-	-
Gear pump with capacity at max. speed (lt/1'):	65	98	98	114	120
Max operational pressure (bar):	260	260	260	230	240

TRANSMISSION	T40	T50	T60	T70	T80
Electronically controlled single-speed hydrostatic transmission Vario System EVO2	-	-	-	-	-
Hydrostatic transmission with variable capacity pump and hydrostatic engine with automatic adjustment	•	•	•	•	•
Number of speeds, forward-reverse	2-2	2-2	4-4	4-4	2-2
Servocontrolled 2-speed gearbox.	No	No	•	•	No
Inching pedal for controlled advancement	•	•	•	•	•

DIFFERENTIAL AXLES - STEERING	T40	T50	T60	T70	T80
Rigid Axles: 2, with planetary gearheads	•	•	•	•	•
Front axle fixed to the frame	•	•	•	•	•
Oscillating rear axle with total range	25°	25°	25°	25°	25°
Oil bath service braking on the 4 wheels with servo brake	-	-	-	-	•
Service brake in oil bath on the front servo controlled axle	•	•	•	•	-
Parking brake with negative operation	•	•	•	•	•
Articulated frame steering, total steering angle:	80°	80°	80°	80°	80°
Servo controlled steering through hydraulic steering gear (Load Sensing)	•	•	•	•	•

TYRES	T40	T50	T60	T70	T80
Tyres	12.5 - 18	14.5 - 20	405/70 - 20	405/70X24	15,5X25
Alternative	365/70R18	405/70R20	420/75R20	460/70X24	460/70X24
Alternative	405/70R18	500/45 - 20	500/45 - 20	600/50-22.5	500/70x24
Alternative	500/45 - 20	600/40 - 22,5	600/40 - 22,5	-	600/50-22.5

REFUELLING (Litres)	T40	T50	T60	T70	T80
Hydraulic system (total)	70	78	80	110	120
Diesel tank	75	100	100	140	153
AdBlue tank	-	-	-	-	27

PERFORMANCE	T40	T50	T60	T70	T80
Tipping load with aligned machine (retracted boom) (Kg)	3600	3850	4050	4800	6100
Tipping load in max articulated position (retracted boom) (Kg)	3200	3400	3575	4250	5400
Tipping load with aligned machine (extended boom) (Kg)	2100	2450	2350	2500	3200
Tipping load in max articulated position (extended boom) (Kg)	1850	2000	2050	2350	2800

Data for machines with quick attachment

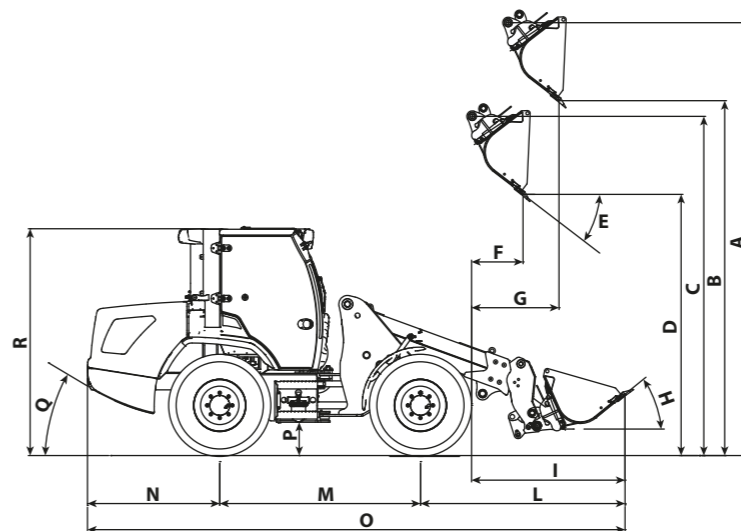

DIMENSIONS	T40	T50	T60	T70	T80
A	4315	4745	5010	5250	5440
B	3460	3890	4155	4300	4470
C	3405	3720	3840	4015	4130
D	2550	2860	2990	3060	3160
E	40°	40°	40°	40°	40°
F	435	565	610	400	480
G	785	960	1060	880	980
H	40°	40°	40°	40°	40°
I	1605	1680	1805	1670	1780
L	2100	2240	2365	2300	2400
M	2150	2200	2200	2400	2550
N	1400	1450	1450	1550	1675
O	5650	5890	6015	6250	6640
P	300	365	365	410	400
Q	30°	31°	31°	31°	30°
R	2420	2490	2490	2690	2700

Measurements expressed in millimetres

PERFORMANCE	T40	T50	T60	T70	T80
Operative load EN474.3 (80%) retracted (Kg)	1800	2200	2250	3000	3500
Operative load EN474.3 (60%) retracted (Kg)	1500	1600	1725	2300	2600
Operative load EN474.3 (80%) extended (Kg)	1250	1300	1300	1650	1800
Operative load EN474.3 (60%) extended (Kg)	950	1000	1050	1300	1500

Data for machines with quick attachment

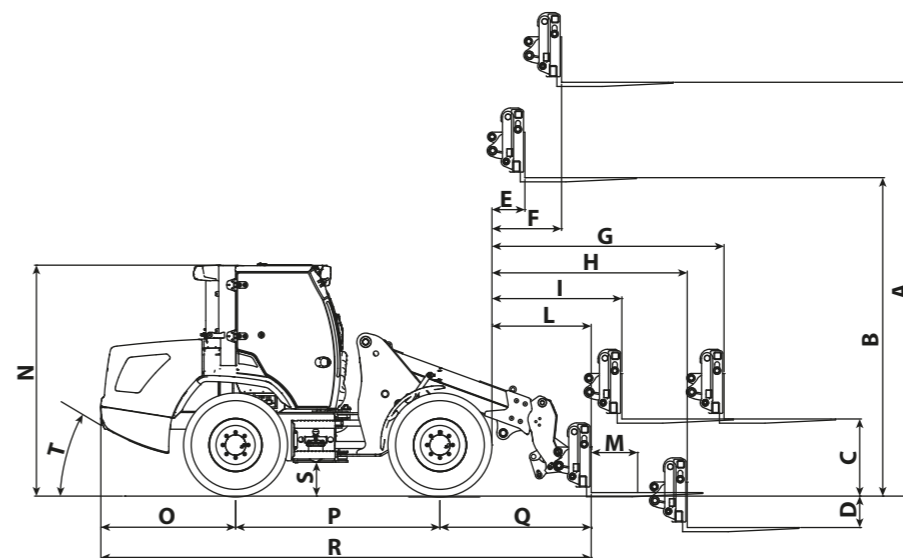

DIMENSIONS	T40	T50	T60	T70	T80
A	4000	4460	4720	5000	5200
B	3070	3430	3550	3750	3865
C	710	830	830	900	1500
D	365	340	435	630	430
E	500	355	405	100	145
F	910	750	850	550	640
G	2290	2500	2780	2625	2825
H	1910	2100	2365	2000	2350
I	1315	1400	1530	1300	1445
L	990	1070	1190	900	1030
M	500	500	500	500	500
N	2420	2490	2490	2690	2700
O	1400	1450	1450	1550	1675
P	2150	2200	2200	2400	2550
Q	1485	1630	1750	1570	1670
R	5035	5280	5400	5520	5895
S	300	365	365	410	400
T	30°	31°	31°	31°	30°

Measurements expressed in millimetres

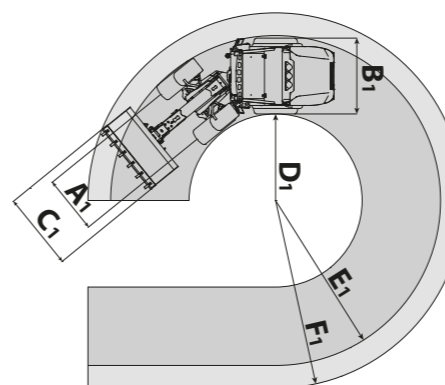

DIMENSIONS	T40	T50	T60	T70	T80
A1	1350	1430	1430	1560	1660
B1	1675	1880	1880	1980	2070
C1	1700	1900	2000	2100	2200
D1	2120	2060	2060	2400	2560
E1	3830	4010	4010	4450	4680
F1	4370	4570	4670	5000	5300

Measurements expressed in millimetres